

WIDE-CUT TRU-CUT



*Model HS-70 Bandmill
on Groundbed Track*

BANDMILLS & SLAB SURFACERS



Hello from Coblantz Fabrication, a small family owned and operated business. Combined with several dealers as well as other local machine & fabrication shops, we specialize in building and marketing wide-cut bandmills and equipment for the live-edge table top slab, long timbers for timber framed buildings and crane mat markets.

We realize when you are in the market for a new sawmill you have many options that can make the purchasing process confusing. We have no desire to sell you a mill that doesn't fit your operation and needs. Every mill has it's limitations; a small hobby mill is not the proper match for a high-production pallet operation. Neither is a large circular mill the proper choice to convert high-value logs into quality masterpieces. We have put a lot of effort into designing and building cost-effective and well-built mills with track options for maximum versatility.

Here are a few areas on our mills where we have added value, these features are normally only available on large commercial mills.

#1 - Chrome cylinder rods with wiper seals and bronze bushings for smooth up and down maintenance-free head movement.

#2 - High-quality stress relieved machined and balanced bandwheels with heavy-duty bearing hub system. Manufacturers have a lot of cheaper options in this area.

#3 - Hardened casters and guide wheels

#4 - All-around heavy-duty mill construction

If you have any questions contact your nearest dealer or Coblantz Fabrication. We have mills in operation across the country and may be able to arrange an appointment for you to see one installed at a customer or at Coblantz Fabrication.

- Melvin Coblantz

From Log to Finished Product



Photo Courtesy of Zimmerman Chair



Photo Courtesy of 3C Heritage Craftsman



Photo Courtesy of Zimmerman Chair

Table Top Slabs being air dried underneath an open building



Turn those huge logs into profit!

The heavy-duty and easy to use Tru-Cut Wide Cut Bandmills are designed to handle massive logs, providing many opportunities for profitable and enjoyable home-based milling businesses. The huge logs that were formally of very limited value can now be used to create fine table tops and other creative masterpieces.

Homeowners and even towns frequently need to have huge trees removed that have historical or sentimental value. With these powerful mills you can convert this prized lumber into rustic live edge table top slabs, counter top slabs and more, thus preserving it's value. Longer timber can also be cut for timber frame buildings. In fact, the only cutting length limitation is the length of track system you install for your bandmill!

Many tree removal companies need to get rid of these oversized logs and are looking for drop-off points, this can also be a great way of getting quality slabs out of many different wood species for your customer base.

Meet the **Tru-Cut** Equipment Line!

HS-70

BANDMILL

Approximate Ship
Weight 3,800 lbs.



HS-96

BANDMILL

Approximate Ship
Weight 4,700 lbs.



EHS-70

BANDMILL

Approximate Ship
Weight 4,100 lbs.



EHS-96

BANDMILL

Approximate Ship
Weight 5,000 lbs.

ESS-70

SLAB SURFACER

Approximate Ship
Weight 5,000 lbs.



ESS-96

SLAB SURFACER

Approximate Ship
Weight 5,300 lbs.

SS-70

SLAB SURFACER

Approximate Ship
Weight 4,750 lbs.



SS-96

SLAB SURFACER

Approximate Ship
Weight 5,100 lbs.





Timber Log Bunks (left) work well for Table Top Slab Cutting

When using Concrete Slab Track, Concrete Slab Log Bunks (below) are required for cutting Dimensional Lumber and Beams. The Groundbed is a better choice if you know you will be cutting dimensional lumber that requires clamping.

HS-70 BANDMILL

Approx. Weight = 3,800 lbs.

Walk alongside this power-feed mill instead of pushing through!



For concrete and track specs see diagram on page 21

Shown on Concrete Slab Track with Optional Concrete Slab Log Bunks

HS-96

BANDMILL

Approx. Weight = 4,700 lbs.

The HS-96 is very similar to the HS-70 except 26" wider, built heavier, and geared a bit slower using the same components as the HS-70

The 96" mills guide arms open up to 96" wide between guide wheels to make those extreme cuts. Now you can stay at the cutting edge, providing your customer base with the widest, most unique cuts going into even wider crotches.

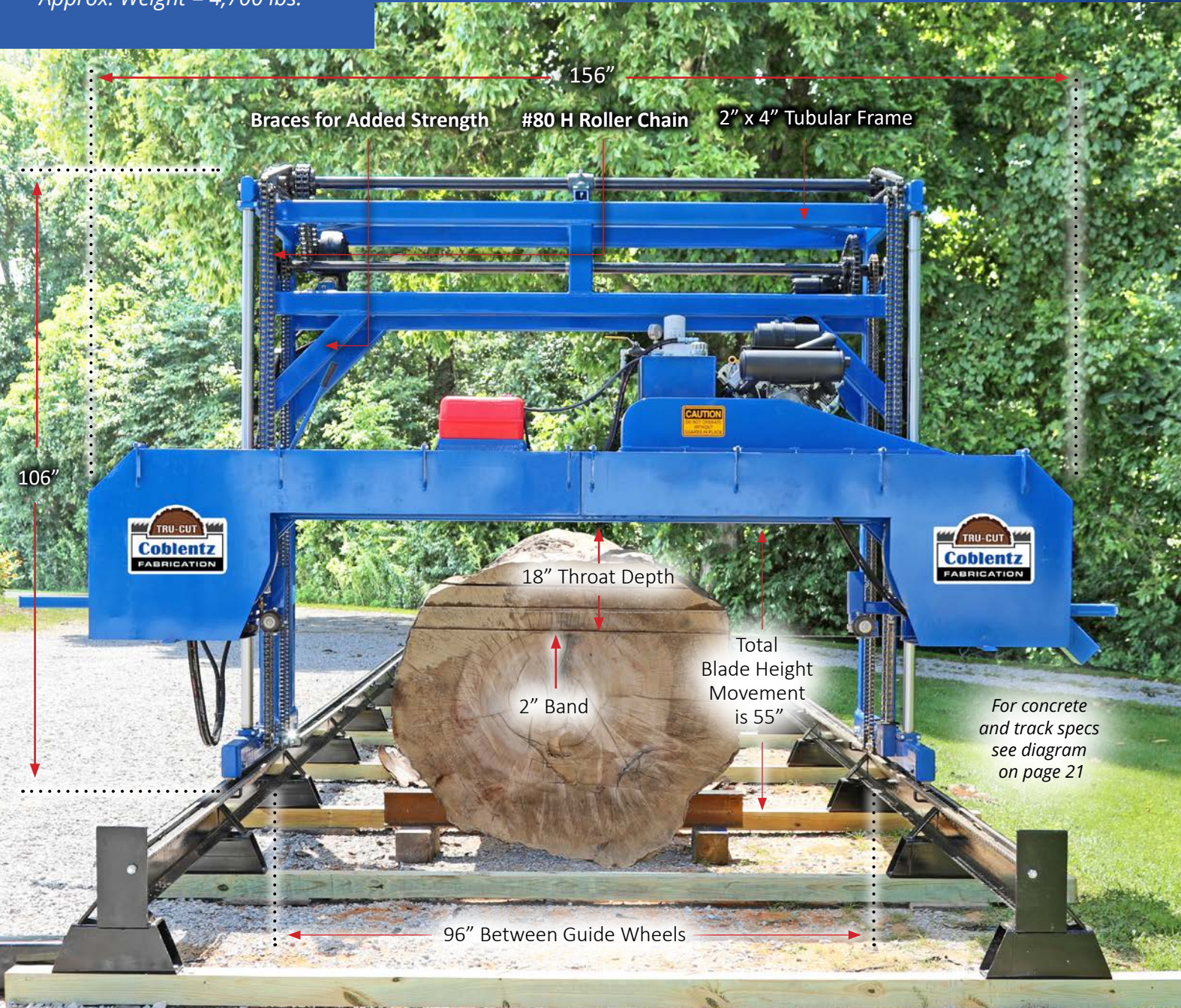

Example of how your mill can go to the logs in a temporary setup

Shown on Concrete Slab Track with Track Riser Blocks



EHS-96
BANDMILL

HS-96
BANDMILL

Front view of the HS-96 on concrete slab track and track riser blocks



Rear view of HS-96 on concrete slab track with track riser blocks. This photo shows how concrete slab track can be set up on 6 x 6 posts in a temporary or remote location to do milling.

The following features differ from 70" mills

Hydraulic motor and gear box used for head lift with double #80 chain from gearbox to headlift shaft

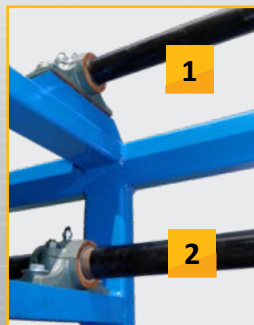

Split journal bearings on powerfeed and lift shafts for convenient maintenance.

- 1** - 2 ¼" top head lift shaft
- 2** - 2" powerfeed shaft

HS-96 and EHS-96



EHS-70

BANDMILL

Approx. Weight = 4,100 lbs.

EHS-96

BANDMILL

Approx. Weight = 5,000 lbs.



The electric mill shown here features a wire support arm that is included with mill and bolted to the top, this can be removed for transport.

The wire support arm is 40" higher than the top of mill frame and extends over the side of mill frame 30". This arm pulls wires along a cable and pulley or a barn door track and trolley system and is hung from this system every 6 - 8 feet. The wire support system is supplied and installed by customer.



Wire Support & Arm available for Right or Left Side of Mill

For concrete & track specs see diagram on page 21

The features of the EHS-96 mill are identical to the HS-96 mill and the features of the EHS-70 mill are identical to the HS-70 mill, except for the electric motor power.

The electrical components shown are standard with all electric model mills and are used on both the EHS-70 and the EHS-96.



Electric motor start/stop switch



Two views of 3 phase 30 HP Techtop electric motor that can be ordered in 230 or 460 volts. These motors have many features and are well proven in industrial applications.



Exterior view of electrical enclosure box with 50' of wire between box and motor being standard which is sufficient for 30' tracks.



Interior view of electrical enclosure - viewing safety disconnect switch, fuses and Fuji Frenica Mega Programmable Variable Frequency Drive that has all the ground fault and short circuit protection, the VFD shown will prevent electrical usage spikes which should help reduce electric energy costs.



Option #1 - Uses a cable and trolleys every 6' to 8' along electric wires



Option #2 - Uses a barn door track and trolleys every 6' to 8' along wires.

Customer supplies cable track and trolleys

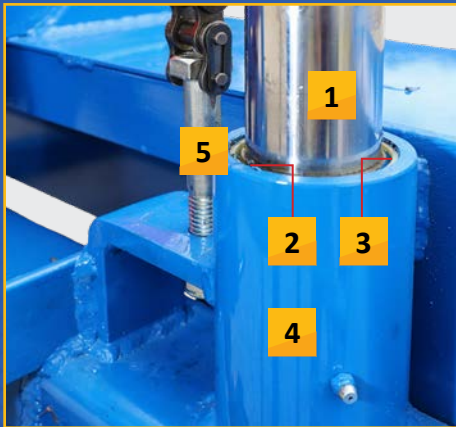

- 1 - 2" Chrome Cylinder Rod for smooth maintenance-free up and down head movement (All Mills)
- 2 - Wiper Seal to keep dirt out and grease in (All Mills)
- 3 - Bronze Bushing inside of round tube below wiper seal for smooth up and down head movement (All Mills)
- 4 - 1 or 2 Pumps Daily of a #0 Grease aids in smooth, maintenance-free head movement (All Mills)
- 5 - Adjusting bolt to provide tension to lift chains (All Mills)

Left Bandwheel

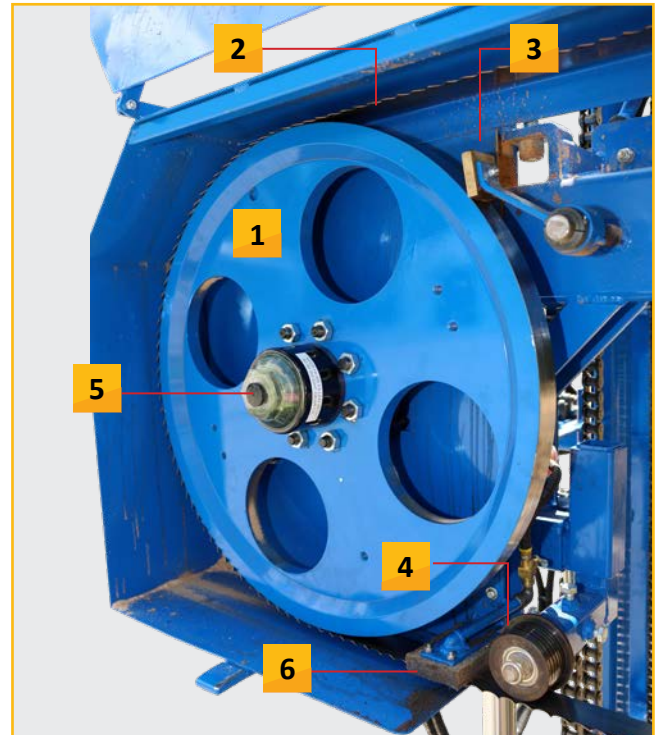

- 1 - High quality stress-relieved, machined and balanced Bandwheels for 2" bands
- 2 - 2" x 340" Band for 96" Mills, 2" x 288" Band for 70" Mills
- 3 - Bronze Bandwheel Scraper eliminates buildup on Bandwheel
- 4 - Adjustable Machined and Hardened Roller Guide Wheels
- 5 - Heavy-Duty Axle Hubs - very easy and economical to service
- 6 - Felt Pad to distribute blade lubrication on band

Tru-Cut Features

- 1 - Filter Gauge & Relief Valve #1 (All Mills)
- 2 - High quality heavy-duty 6 gallon Marine Fuel Tank with Fuel Level Gauge (HS-70, HS-96)
- 3 - Handle that engages Blade Rotation (All Mills)
- 4 - Engine Oil Drain Hose (HS-70, HS-96)
- 5 - 35 HP Briggs Vanguard Engine (HS-70, HS-96)
- 6 - 12 Gallon Hydraulic Oil Reservoir with Sight and Temperature Gauge (All Mills)



Remote Start Panel

This option is available on all mills with gas-powered engines and consists of a panel with key switch, hour meter, choke and throttle cable, all conveniently located on the operator side of mill.

Right Bandwheel

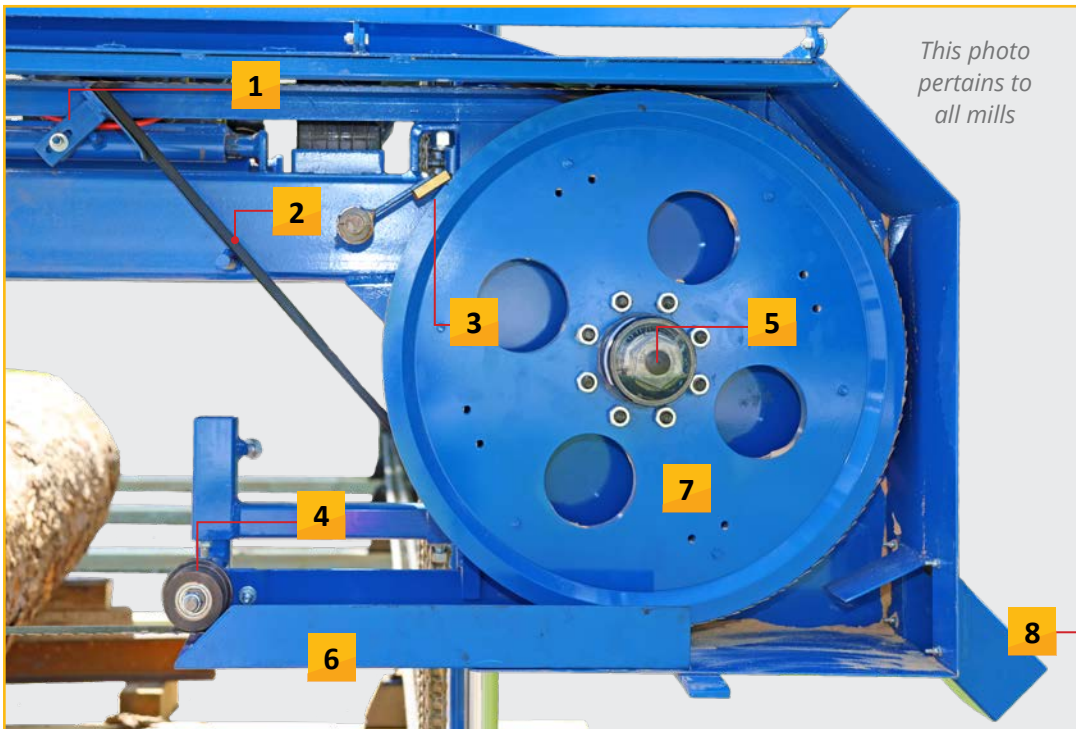

- 1 - Belt Support helps blade come to a complete stop when bandwheels are disengaged
- 2 - 3B Belts on Driver Pulley 3 - Bronze Bandwheel Scraper eliminates buildup on Bandwheel
- 4 - Adjustable Machined and Hardened Roller Guide Wheels
- 5 - Heavy-duty Axle Hubs very easy and economical to service
- 6 - Sawdust Chute helps move sawdust on out the side
- 7 - High quality stress-relieved, machined & balanced Bandwheels for 2" bands
- 8 - Sawdust Hose Adapter - 6" square to round adapter that bolts to any of our mills.
For connecting 6" round flexible dust collection hose to a sawdust blower.

HS-70

BANDMILL

HS-96

BANDMILL

EHS-70

BANDMILL

EHS-96

BANDMILL

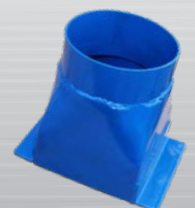

Tru-Cut Features

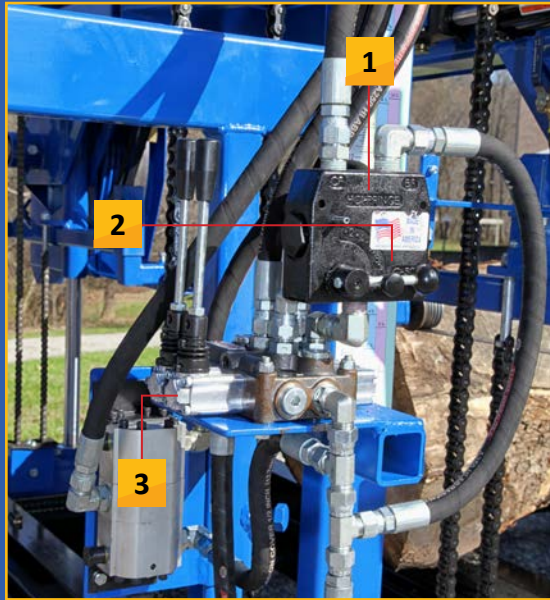

Hydraulic Valve Bank with Flow Control to adjust Carriage Speed

- 1 - Flow Control used for speed control when sawing large logs
- 2 - Control Knob
- 3 - Valve Bank and Relief Valve #2

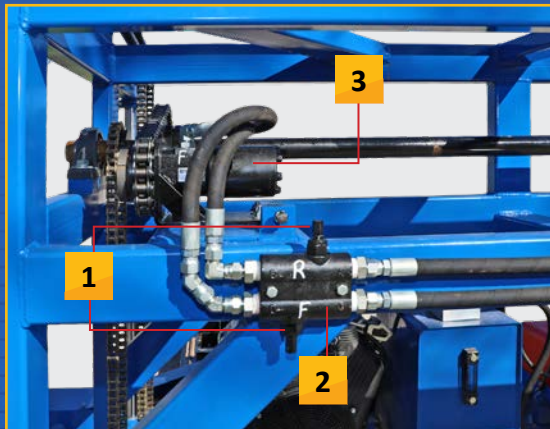

Double Cross Over Relief Valve and Hydraulic Powerfeed Drive Motor (Relief Valve #3)

- 1 - Caps and Adjusting Set Screws
- 2 - Double Cross Over Relief Valve needs to be adjusted after saw is placed on track (Refer to Owner's Manual)
- 3 - Hydraulic Powerfeed Motor

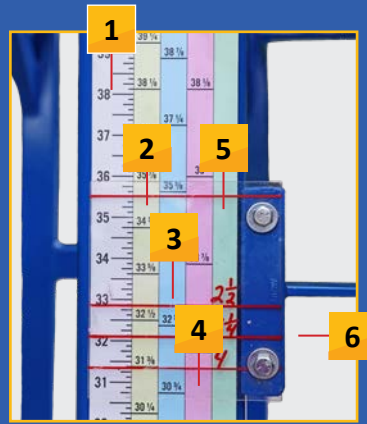

- 1 - Main Scale
- 2 - Scale for 1" Lumber
- 3 - Scale for 1 1/2" Lumber
- 4 - Scale for 2" Lumber
- 5 - Create your own scale in this column
- 6 - These lines used when cutting 2 1/2", 3 1/4", and 4" Table Top Slabs

2 Views of Hydraulic Motor and Gear Box used for Head Lift



- 1 - #60 H Roller Chain for 70" Mills
#80 H Roller Chain for 96" Mills

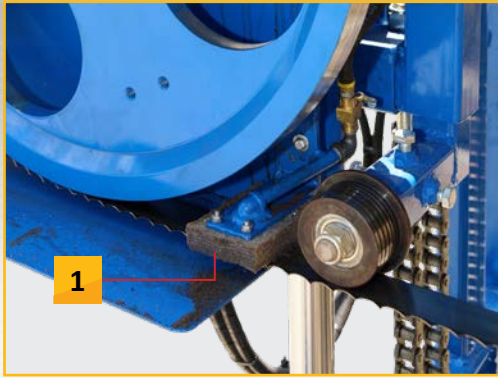

1 - Felt Pad to distribute blade lubrication on band

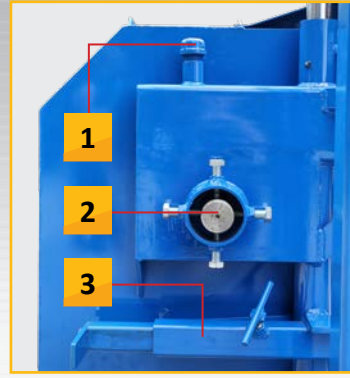

- 1 - Blade Lubrication Fill Spout in Main Beam
- 2 - 4-Bolt Band Wheel and Blade Tracking System
- 3 - In and Out Guide Wheel Adjustment

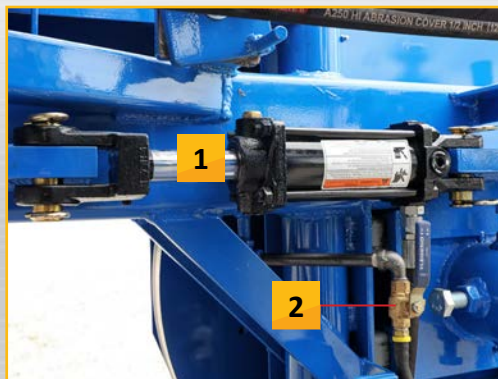

- 1 - Blade Tension Cylinder
- 2 - Blade Lubrication On-Off Valve

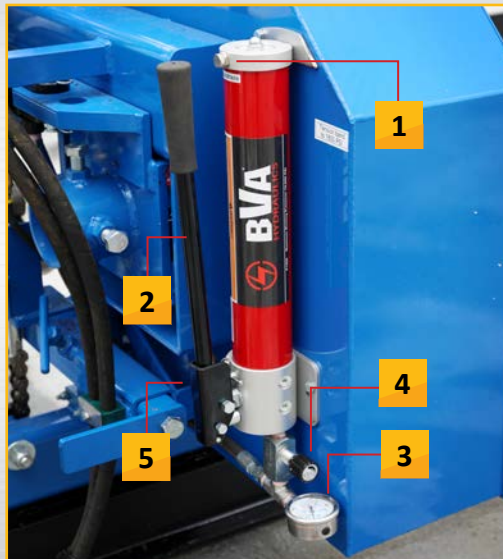

- 1 - Air Vent Knob
- 2 - Hydraulic Hand Pump used to tension band
- 3 - Gauge shows proper band tension
- 4 - Flow Control Valve with Check Valve Knob can be left closed to pump up pressure but must be opened to release pressure.
- 5 - Must be closed to apply band pressure, but must be opened to release band pressure.

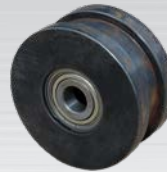

Hardened Casters used on all Sawmills. Bearings can be replaced by removing retaining rings.

Hardened Casters and Bronze Track Scrapers on 3/4" x 3/4" Rail



HS-70
BANDMILL

HS-96
BANDMILL

EHS-70
BANDMILL

EHS-96
BANDMILL

Applies to Page 12 & 13



SS-96 Slab Surfacers
(No clamping system shown)

Dried and surfaced
slabs ready for sale

Tru-Cut Slab Surfacers

Welcome to the newest set of machines in the Tru-Cut Equipment Line! Complimenting our existing equipment line, the Tru-Cut Slab Surfacers are rugged industrial machines developed through customer feedback, and the need for higher speed and performance, to improve inconvenient slow and labor processes, currently being used for planing and sanding tabletop slabs and other large surfaces.

The Tru-Cut Slab Surfacers are designed and built for flexibility and performance with 18" vertical movement to plane and sand large timbers. The SS-70 and ESS-70 Surfacers have a horizontal side to side coverage of 73". The SS-96 and ESS-96 has a 99" side to side coverage to accommodate your largest slabs. With plenty of choices on custom length tracks, these machines are ready to take your woodworking and markets to the next level.

Several other points of consideration:

#1 - If you are cutting and selling your live edge slabs green, the current market would indicate some species of slabs double or triple in value when dried and planed, ready to be made into tables or furniture. Which is adding significant value to your product.

#2 - If you are a furniture builder using large slabs for tables or counter tops, you should be able to buy your slabs considerably cheaper if you finish them.

#3 - The SS-70 & ESS-70 Slab Surfacers will operate on the same track as our 70" Mills.

The SS-96 and ESS-96 Slab Surfacers will operate on the same tracks as our 96" Mills. So if you already have one of our Mills with Groundbed tracks we can supply you with slab clamps for your existing Groundbed Track, so that your slab surfer can store on one end of your Groundbed Track while your sawmill is in use or vice versa. We can also provide you with a complete package with custom-length Groundbed Track featuring clamps, spaced for your needs. If you need any assistance in the purchasing and set-up stages - please call us or contact your Tru-Cut dealer.

SS-96 and ESS-96 can be mounted on tracks for 96" Mills, and SS-70 and ESS-70 Surfacer can be mounted on tracks for 70" Mills. Surfacer can be moved to end of track when using your Band Mill!

SS-70

SLAB SURFACER

Approx. Weight = 4,750 lbs.



Slab Surfacer Features

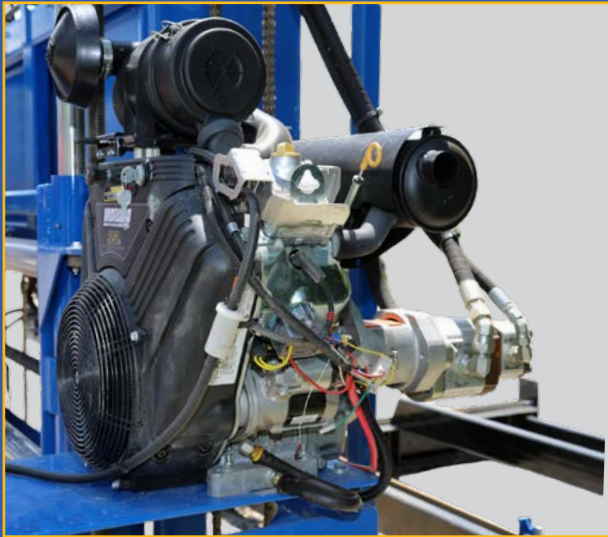

Engine shown with 2 Direct Drive Hydraulic Pumps to power machine. Engine oil drain hose shown.



- 35 HP Briggs Vanguard Engine is mounted on rubber isolated plate large enough to add optional dust collection blower that can be powered with existing engine.
- Manual Canister mounted in an out-of-the way location
- 6 Gallon High-Quality Marine-Grade Fuel Tank w/ fuel level gauge

SS-70
SLAB SURFACER

SS-96
SLAB SURFACER



Sawdust Blower (optional)
Approx Weight = 175 lbs

Blower Belt Guard removed to show clarity



Showing Sawdust Blower with Guard in place.



Sawdust Blower (optional)
Approx Weight = 225 lbs

Another view of Sawdust Blower with 5HP 3-Phase Tectop Motor for Power Source.



Shows Electric Motor stop-start switch conveniently located above hydraulic controls.

Outside of Safety Disconnect Enclosure, provided with Electric-powered Slab Surfer.



Inside of safety disconnect enclosure, provided with Electric-powered Surfacers. Showing disconnect switch, soft start for 30HP motor, and adjustable time delay for 5 HP blower motor. These motor controls allow for smooth starting and eliminate high power usage spikes, which helps reduce energy costs.



30 HP 3-Phase Electric Tectop Motor direct coupled to Tandem Hydraulic Pumps. Also showing Sawdust Blower.

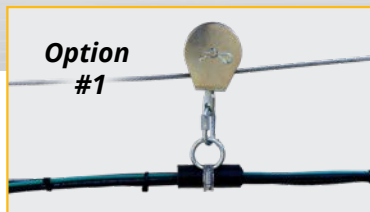

Uses a cable and trolleys every 6' to 8' along electric wires



Uses a barn door track & trolleys every 6' to 8' along wires.

Customer supplies cable track and trolleys

ESS-70
SLAB SURFACER

ESS-96
SLAB SURFACER

Slab Surfacers *Features*



SS-70
SLAB SURFACER

SS-96
SLAB SURFACER

ESS-70
SLAB SURFACER

ESS-96
SLAB SURFACER

Viewing Hydraulic Valves, Flow Controls, and Gauges.

Hydraulic valves are used to engage cutterhead and power feed, as well as moving cutterhead left to right. Fourth hydraulic valve with bent handle is for optional power lift instead of handcranking, for vertical movement of cutterhead. Flow controls are used for adjusting speeds on Cutterhead and Sanding Head. Also for adjusting travel speed along track. When planing or sanding, flow control valve on right adjusts powerfeed, travel speed, cutterhead pressure gauge needs to maintain a pressure between 1000 - 1500 PSI for SS-70 and SS-96 gas-powered slab surfacers, and a pressure between 1500-2200 for ESS-70 and ESS-96 electric-powered Slab Surfacer, while planing and sanding.

Applies to Page 18 & 19

Viewing Hydraulic Motor and Gear Reducer, used to power Slab Surfacers along track.



Powerfeed Chains & Idler Sprockets

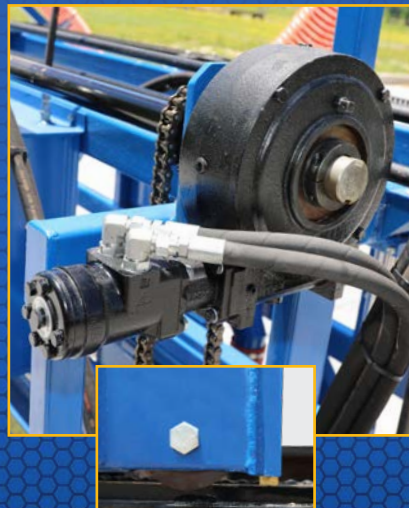

Close-up View of Caster Rail, Caster and Bronze Track Scraper used for keeping tracks clean.



Viewing 90 Gallon Hydraulic Oil Reservoir with Return Filter and Oil Level Temperature Gauge

Rear View of Horizontal Scale, 3" Chrome Rods, Ball Screw, and Linear Bearing all used to achieve a 73" horizontal cutterhead coverage for models SS-70 and ESS-70. A 99" coverage for models SS-96 and ESS-96.

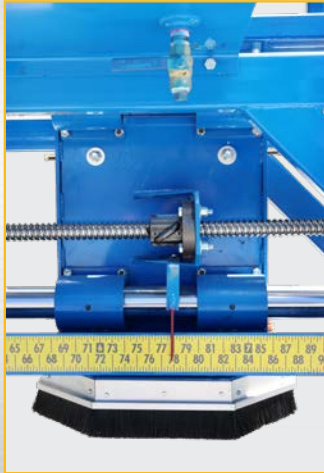

Viewing the heart of the machine



Viewing front side of Cutterhead Guard with flexible bristle brush, which creates a vacuum seal against material being surfaced, so the dust collection blower can remove wood shavings. Also 1-1/2" Cutterhead Shaft going through top of dust collection hood.



Viewing Hydraulic Cutterhead Motor, Rubber Coupler, Bearing, and Cutterhead Arborshaft



- Viewing Engine Controls. Key Switch, Choke and Throttle conveniently located on operator side of machine (SS-70 & SS-96).
- Viewing Vertical Scale. Showing height of cutterhead off of bed. Also 2" chrome cylinder rods, 1/4 precision acme screws used for vertical positioning of cutterhead. Cutterhead has 18" of vertical movement allowing for planing and sanding of large timbers.
- Side View of Hydraulic Motor, Ball Screw, 3" Chrome Cylinder Rod, and Linear Bearings.

- Angle View of Track Lube Reservoir used to put small amounts of lubricant on track to assist scrapers in keeping track cleaned as necessary.
- Also viewing ratcheting handle and gear reducer used for precise vertical adjustment of cutterhead. One round of handle moves cutterhead 1/32". Also available with Powerlift option. See other photo.



Viewing 14" diameter 12-Tooth Replaceable Carbide Cutter with adapter machined in bottom to receive sanding head.

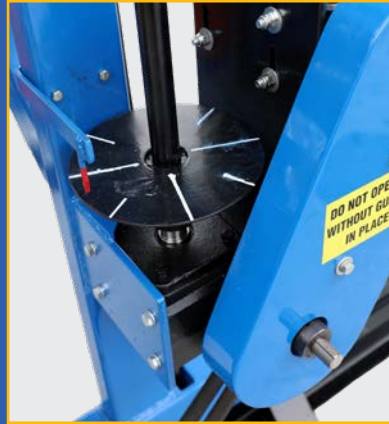

Indicator Wheel used by operator when micro-adjusting the cutter-head vertically when sanding.



16" Diameter Sanding Head attaches to bottom of cutterhead with a quarter turn twist lock. When finished planing, simply attach sanding head to bottom of cutterhead. With a simple quarter turn twist lock raise head several inches and you are ready to sand.



Hydraulic motor powers a 20-1 Gear Reducer for powerlift of Cutterhead.

SS-70
SLAB SURFACER

SS-96
SLAB SURFACER

ESS-70
SLAB SURFACER

ESS-96
SLAB SURFACER

End View of Groundbed with Clamps for planing and sanding, tabletops or any large surfaces. The clamps on the 70" Groundbed have the ability to clamp up to 65" wide. The clamps on the 96" Groundbed have the ability to clamp up to 99" wide surfaces. One of the best features of our slab surfacers is, they will operate on the same tracks as our Mills. The Slab Surfacers can also be stored on 1 end of the track while Mill is in use. Or we can build a separate track if you prefer to have your sawmill and Slab Surfacers set up at different locations.



Concrete Slab Track Installation Guide

I-Beam Track on top of Concrete Slab (Concrete Slab provided by Customer)

Track Measurements for 70" and 96" Mills and Slab Surfacers

STOP

You may need to consult a local structural engineer to design your slab. Design may change depending on climate and soil type. Coblenz Fabrication is not responsible for slab design or failure.

Mill Carriage Shown without Head for Clarity

Beams need to be installed using a laser transit and shimmed with steel shims to ensure perfectly level track.

I-Beams tracks are installed by customer.

Concrete Slab provided by customer.



Custom I-Beam Track Length Available. Call for Pricing

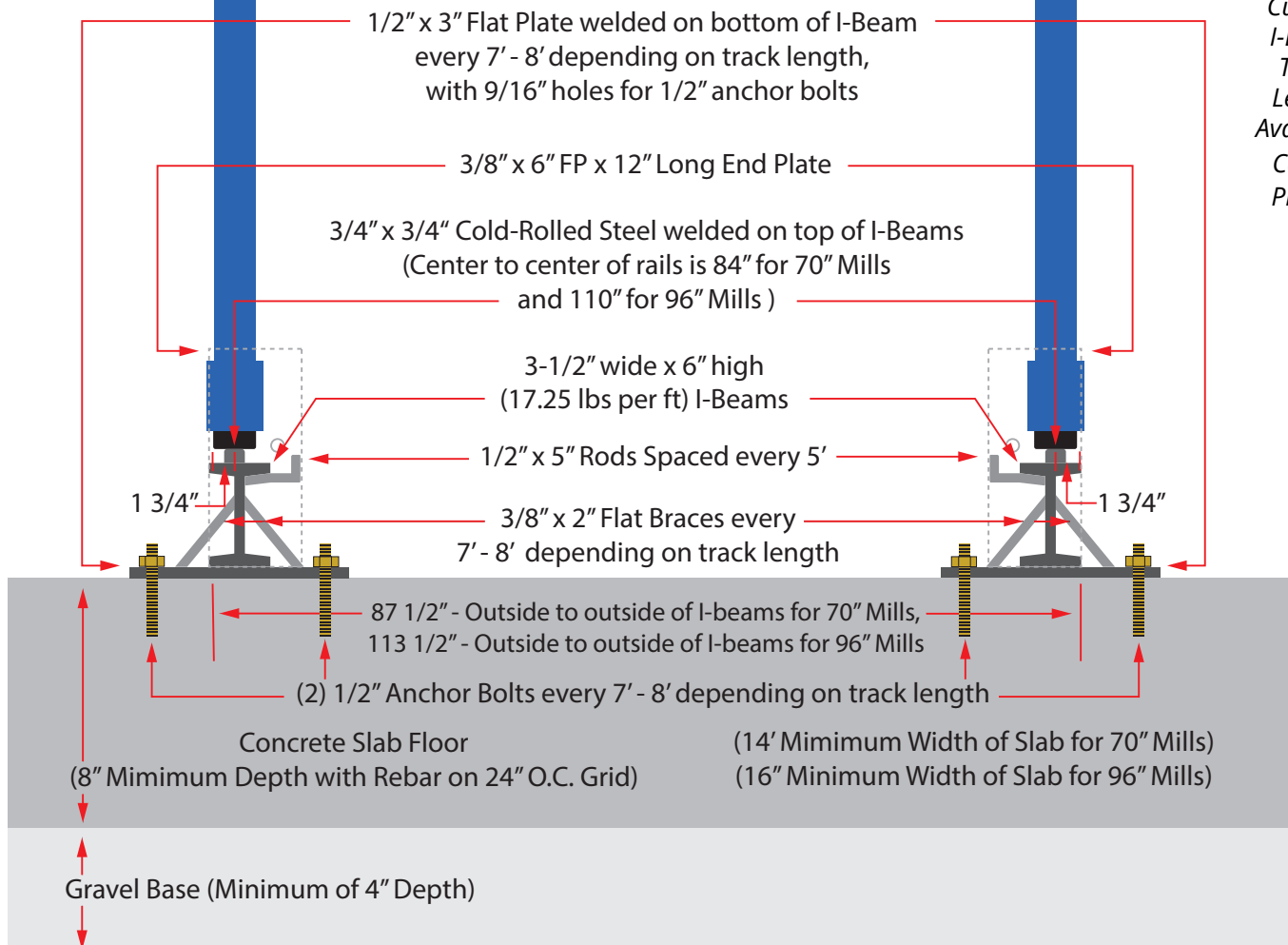

I-Beam Track on top of Concrete Slab

Details of Concrete Slab



HS-70
on Concrete Slab
Track. See page 21
for concrete slab
track specs and
diagrams

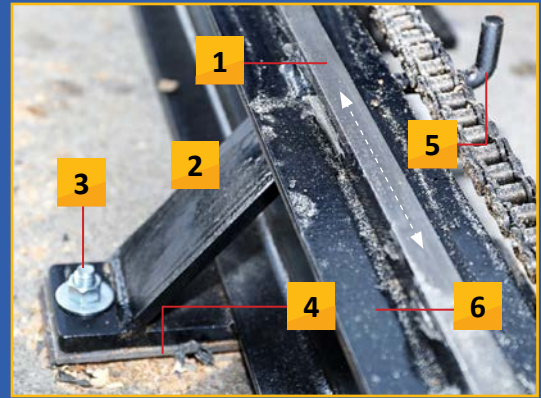

- 1 - Caster Rail
- 2 - Brace
- 3 - 1/2" Anchor Bolt
- 4 - Metal Shim
- 5 - Chain Support
- 6 - 6" x 17.25 lbs. per ft I-beams

Concrete Slab Log Bunk from Log Clamp End



- 1 - Heavy-Duty Sliding Cam Action Style Log Clamp
- 2 - Handle operates square arm on opposite side
- 3 - Jamb Bolt puts tension on square arm to hold at proper height

Concrete Slab Log Bunk #1 shown from Fold-Down Square Arm Side



- 1 - Fold-down Square Arm folds down with handle on opposite side

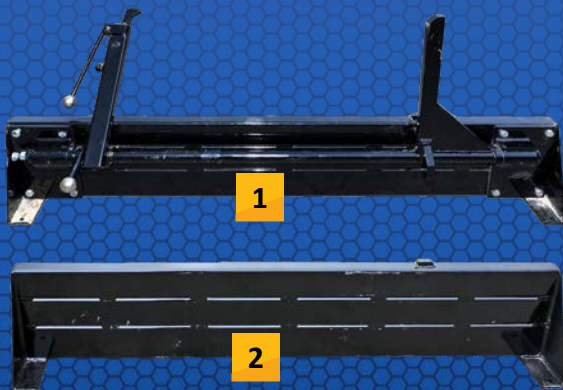

- 1 - Concrete Slab Log Bunk #1 w/ Log Clamp & Square Arm
- 2 - Concrete Slab Log Bunk #2

Groundbed

Approx. Weight = 4,250 lbs.

The 70" Sawmills and Slab Surfacers operate on the 70" Groundbeds.
The 96" Sawmills and Slab Surfacers operate on the 96" Groundbeds.



HS-70 on 35' Ground Bed with 6" Track Risers, (3) Log Clamps and Square Arms

Groundbed with Slab Clamps mounted, ready to add a Slab Surfer to this end.

Log Clamps and Square Arms spacing and amount can be customized to your needs!

Ground Bed View from Log Clamp Side

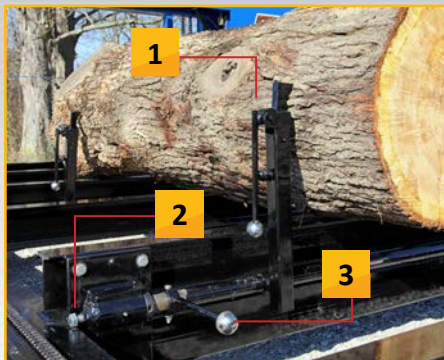

- 1 - Heavy-duty Sliding Cam Action Style Log Clamp
- 2 - Jamb Bolt puts tension on square arm to hold at proper height
- 3 - Handle that operates square arm on opposite side

6" Track Riser as shown on page 7



Raises the tracks or ground bed 6" and makes easier cleanup

Ground Bed View from Square Arm Side



1 - Fold-down Square Arm folds down with handle on opposite side

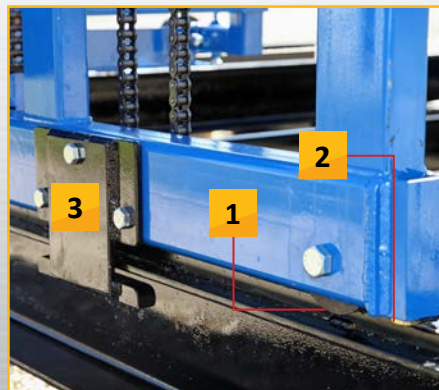

- 1 - Hardened Casters
- 2 - Bronze Track Scraper
- 3 - Hold-down Bracket (keeps Mill from derailing from track)

Power Feed Chains and Chain Idler Sprockets Installation View

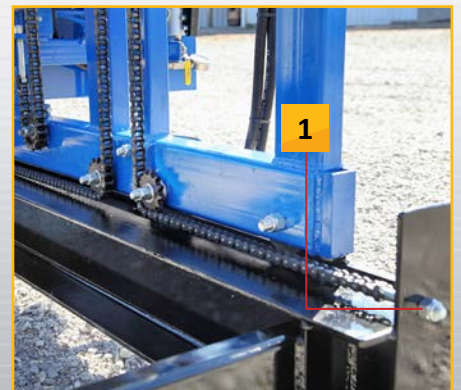

1 - Bolt to tension Power Feed Chain

WIDE-CUT



*HS-70 Band Mill
on 35' Ground Bed*



*HS-70 Band Mill and
SS-70 Slab Surfer*

TRU-CUT BANDMILLS & SLAB SURFACERS

Limited Product Warranty

| Product | Length of Warranty | Effective Date |
|--|--------------------|---------------------------|
| Engine | 3 years | Date of original purchase |
| Workmanship, Manufacturing by Coblentz Fab | 2 years | Date of original purchase |
| Most Components | 1 year | Date of original purchase |
| Electric Motors and Components | 1 year | Date of original purchase |

*All Warranties are subject to Coblentz Fabrication Approval